



INSTALLATION INSTRUCTIONS FOR ESCORT IX RADAR DETECTOR



**ALUMINUM
THREADED
INSERT**



**UNSCREW
HERE**

1 - The magnet must be removed from the suction cup mount that the radar detector came with.



BOLT

MAGNET

2 - Unscrew and remove bolt, only the magnetic peice is used with the blendmount.

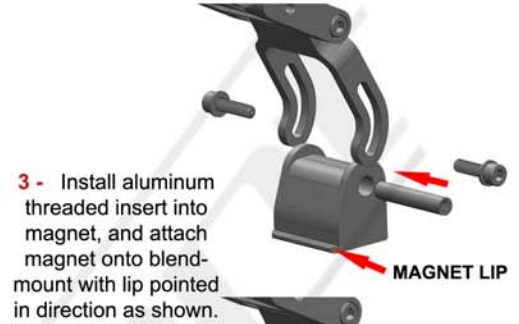

3 - Install aluminum threaded insert into magnet, and attach magnet onto blend-mount with lip pointed in direction as shown.

MAGNET LIP



3/4" INNER DIAMETER WITH BUSHINGS **7/8" INNER DIAMETER WITHOUT BUSHINGS**

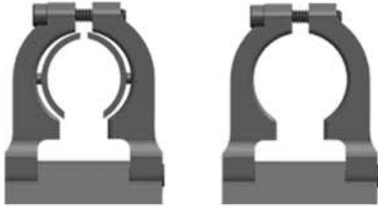

4 - This mount was designed to fit rear view mirror stems that are 3/4" or 7/8" in diameter. If the mount is too big to clamp onto your mirror stem, use the two bushings.

Grab the mirror and move the stem upward using the windshield pivot only



STEM

WINDSHIELD PIVOT

MIRROR PIVOT

Mirror stem can pivot left/right to point radar detector where desired



5 - Most compatible mirrors have a stem between the mirror and the windshield that has a pivot on both ends. We recommend that you try moving the mirror upward before installing the mount. Grab the mirror and move the stem upward using the windshield pivot only. Adjust the mirror to your normal viewing position using the mirror pivot only. Notice the higher location of the mirror as shown above. **NOTE: The mirror stem may move side to side as well. Make sure the stem points straight ahead so the RD does too.**

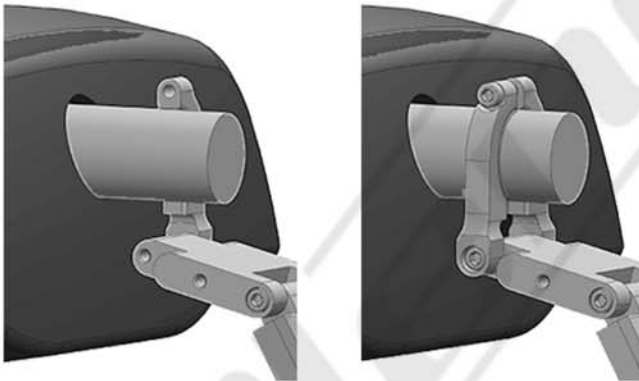

6 - Install the mount while sitting in the passenger side of your vehicle. Remove the right-top portion of the mount and position the mount around the mirror stem as shown above. Reattach the right side of the mount. Make sure the lock washer is still on the lower clamp screw. Leave the top screw loose so the mount can slide along the mirror stem and rotate to the desired location. There may be a plastic oval clip around a wire and the stem, the clip must be removed to install the mount. **Lightly snug screws, do not fully tighten until last step.**

BLENDMOUNT CENTER LINK

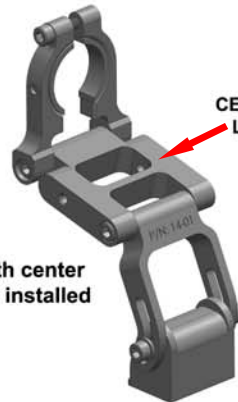

With center link installed

CENTER LINK



Without center link installed

7 - The center-link may be removed if an overall shorter mount length is needed, depending on your rear view mirror and desired position for the radar detector.



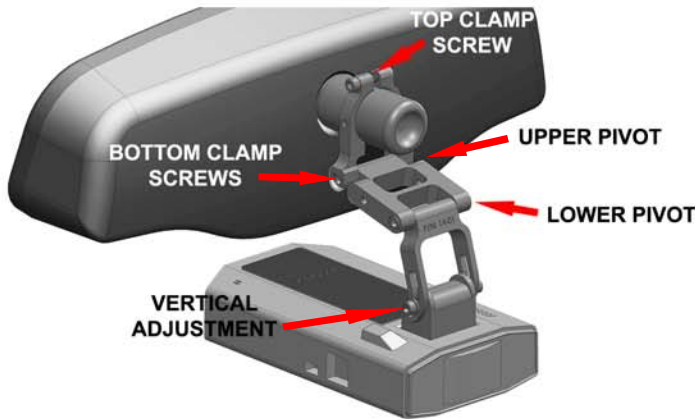

8 - Install the RD onto the mount. Make the necessary adjustments as shown above. Using the upper and lower pivots, and the vertical adjustment, leave enough room below bottom of mirror to allow access to buttons on top of radar detector.

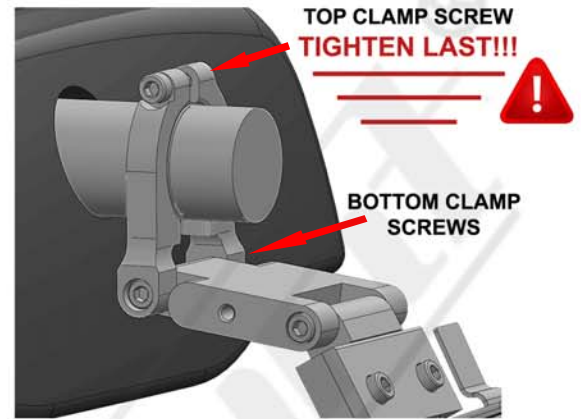

9 - At this point your RD should be positioned where you want it and the screws should be snug. Loosen the top clamp screw so both the lower clamp screws can be fully tightened. Grab the long arm of the allen wrench to assure that these screws are securely tightened, you will not strip out the tapped holes in the aircraft grade aluminum. **The bottom clamp screws should be fully tightened before tightening the top clamp screw. If the top screw is tightened before the bottom screws are, the clamp will loosen over time.**

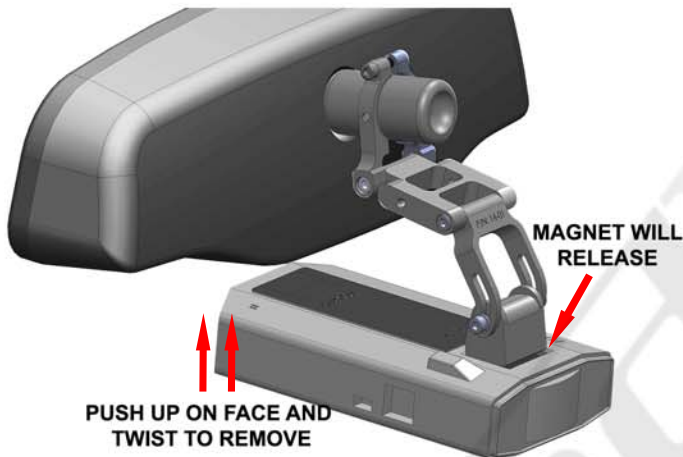

10 - To remove the radar from the magnetic mount, simply tilt the face of the RD up and twist slightly to side, then the magnet will release.



FOR MORE INFO VISIT www.blendmount.com/videos

CAUTION

DO NOT use this mount if it interferes with the adjustability or the operation of your rear view mirror in any way.

DO NOT use this mount if the radar detector creates an unsafe viewing obstruction.

DO NOT ATTEMPT TO MODIFY THIS PRODUCT. Consult the manufacturer for assistance.

All BlendMount products are accompanied with detailed installation instructions and adjustment tips. You are encouraged to contact customerservice@blendmount.com or call J28 Design at 1-888-497-8388 for further assistance.

Check the BlendMount Forum for installation tips and some vehicle specific installs.
www.blendmount.com

Your feedback is very important to us. Please email any questions or comments you have to customerservice@blendmount.com