



Your rear view mirror has minimal clearance between the back side of the mirror and the mirror stem. It is very important that this mount is installed correctly to ensure mirror adjustability is retained.  
**PLEASE READ THESE INSTRUCTIONS THOROUGHLY BEFORE INSTALLING THIS MOUNT**

**NOTE:** For illustration purposes, the mount and rear view mirror shown in these instructions may look slightly different than YOUR mount and rear view mirror.



**BEFORE INSTALLING THIS MOUNT ON YOUR MIRROR** observe how the spring clip functions. **When used properly, the spring clip avoids putting excessive pressure on the mirror when installing and removing the radar detector (RD).** To release tension from the spring clip, simply squeeze the tab and the back side of the mount together. This will lower the bottom portion of the spring clip allowing you to slide the RD on and off the mount. Push the RD Release button and slide the RD onto the Spring Clip as far as it will go. Then release both the Tab and the Release Button. Slide the RD toward you just slightly until you hear it lock into position. Install and remove the RD a few times before installing the mount on your mirror.

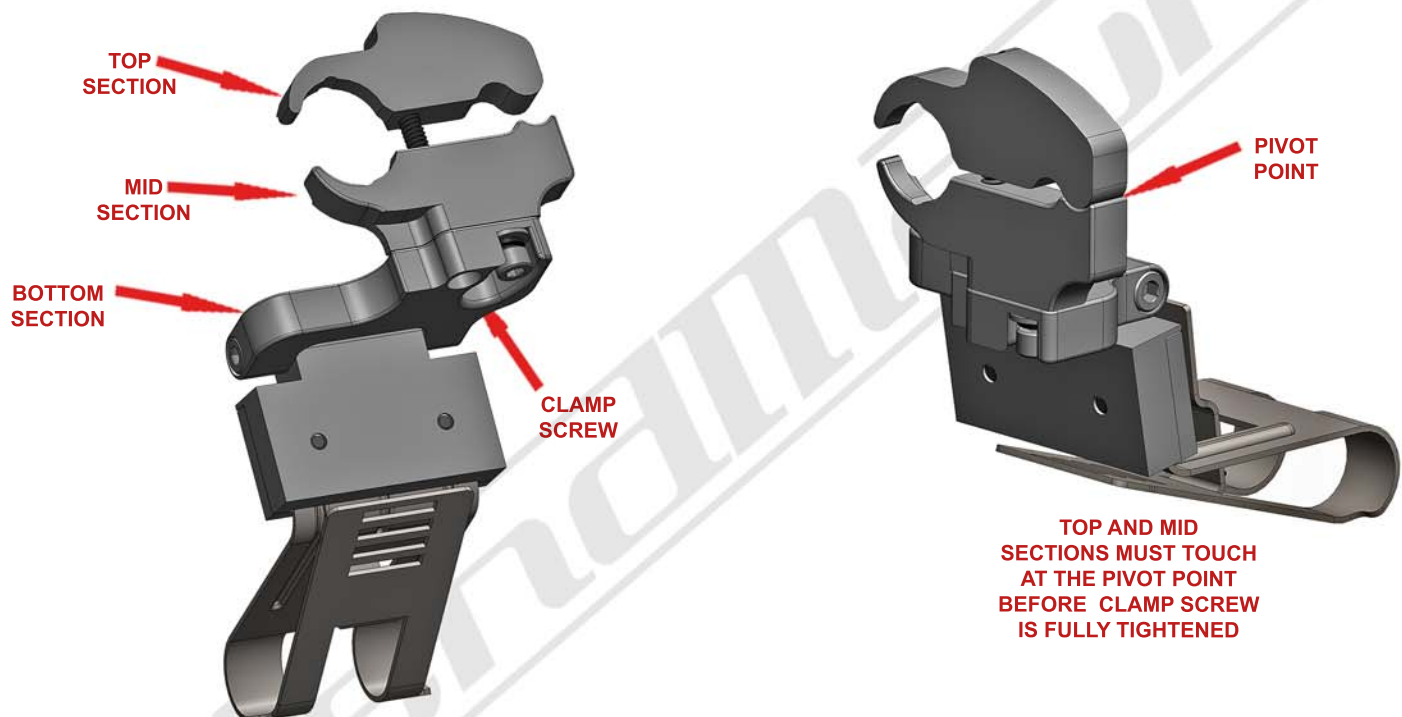

**STEP 1 -** Loosen the clamp screw so the top section separates from the mid section. This will provide the necessary clearance to slide the mount over the mirror stem as shown above. **Adjust the mirror parallel to the windshield and slightly upward for ease of installation.**

**STEP 2 - BEFORE FULLY TIGHTENING THE CLAMP SCREW, POSITION THE MOUNT AS FAR FORWARD TOWARDS THE WINDSHIELD AS YOU CAN. MAKE SURE THE TOP AND MID SECTIONS ARE TOUCHING AT THE PIVOT POINT.** If you can not get them to touch at the pivot point, you have an **incompatible mirror type for this mount.**



**STEP 3** - When the mount is positioned as far forward as it will go, tighten the clamp screw until the Top and Mid Sections are **slightly snug** around the mirror stem. You should still be able to rotate the mount.



**STEP 4** - Rotate the mount so it is parallel with the bottom of the mirror. Tighten the clamp screw until the mount is securely attached to the mirror stem.

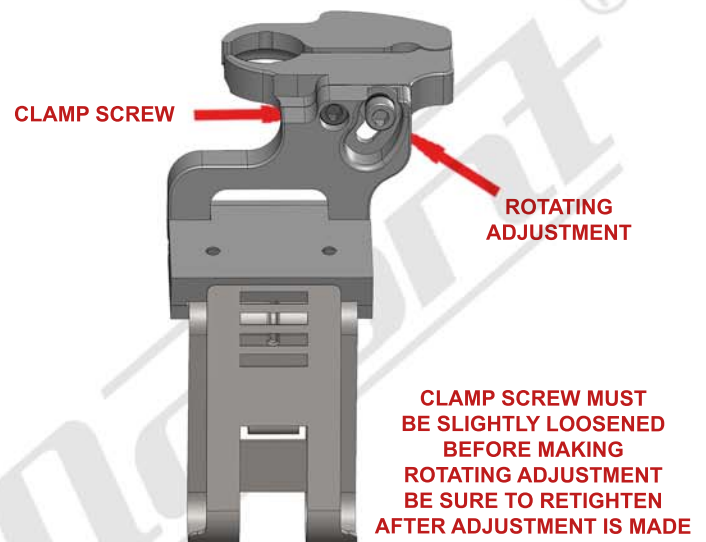
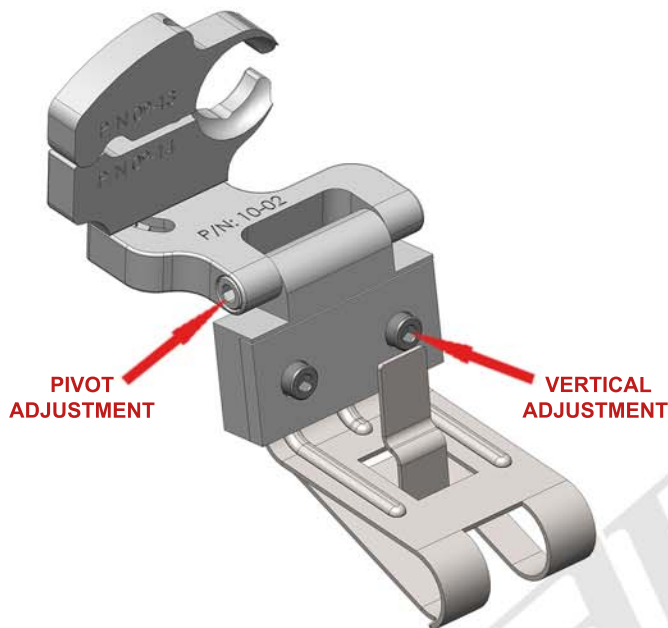

**STEP 5** - Install your radar detector onto the mount. Use the adjustments shown above to adjust the RD to your desired position. We recommend adjusting the RD as close to the bottom of your mirror as you can. Be sure to tighten all adjustment screws after the adjustments are made. For the Pivot adjustment, grab the long arm of the allen wrench for maximum leverage. You will not strip the threaded holes in the aircraft grade aluminum.

### CAUTION

**DO NOT** use this mount if it interferes with the adjustability or the operation of your rear view mirror in any way.

**DO NOT** use this mount if the radar detector creates an unsafe viewing obstruction.

**DO NOT ATTEMPT TO MODIFY THIS PRODUCT.** Consult the manufacturer for assistance.

All BlendMount products are accompanied with detailed installation instructions and adjustment tips. You are encouraged to contact [customerservice@blendmount.com](mailto:customerservice@blendmount.com) or call J28 Design at 1-888-497-8388 for further assistance.

Check the BlendMount Forum for installation tips and some vehicle specific installs.  
[www.blendmount.com](http://www.blendmount.com)

Your feedback is very important to us. Please email any questions or comments you have to [customerservice@blendmount.com](mailto:customerservice@blendmount.com)